

DIAMOND<>FURR® Pat.

LATH ATTACHMENT SYSTEM

PRODUCT ID: DFWD-375

WINDOW DRIP

DESCRIPTION: The Diamond-Furr *Window Drip* edge is a unique patent pending design that offers the first real solution to the moisture intrusion problems that have plagued the plastering industry for decades.

The *Window Drip* (pt # DFD-375) is designed to be used in a 3-coat plaster system just like a conventional drip trim over doors and windows. The Diamond-Furr difference is the built-in furring strip which provides an uninterrupted 3/8" furring as well as a flexible connection point for metal lath. The tie wire connection effectively eliminates 100% of the fastener penetrations through the vapor barrier at these critical points. It also means that the lath never comes in contact with the moisture barrier which removes the probability of accidental tears in the last line of defense by over tightened screws.

Another advantage of the Diamond-Furr drip edge is that it removes the need for additional petroleum based peel and stick moisture barrier products which allows the plaster at the termination point to reach the full 7/8" depth.

We recommend using the Diamond-Furr Termination Trims in conjunction with the ICC approved Diamond-Furr *Furring Strips* for a complete system and the utmost protection against moisture intrusion through the building envelope.

MATERIAL: 26 GA Galvanized Steel G90, Also available in Stainless Steel – Call for Details

ASTM : A653, LFQ, C1063, C841, C847, A653, C1047, A924, Fed. Spec QQ-S-775-D,

LENGTH: Standard: 10 ft.

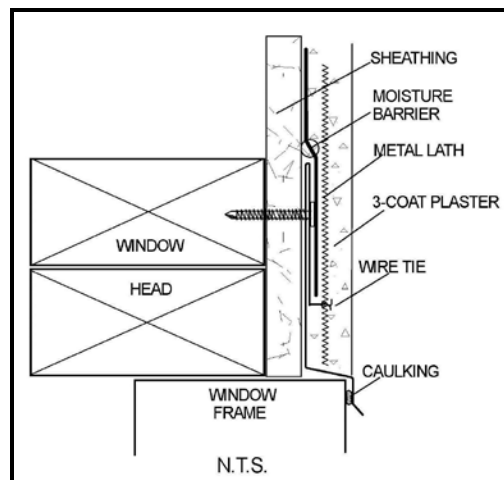
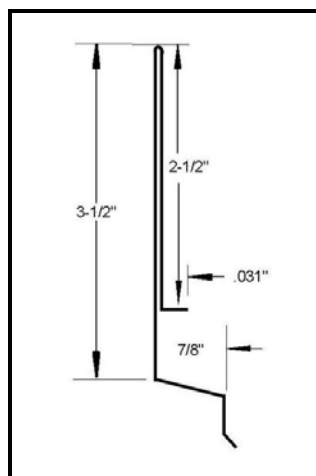

BRAND X METALS, INC.

1641 So. Sinclair Street ♦ Anaheim, CA 92806 ♦ PH: (714) 978-3600 ♦ FAX: (714) 978-3601

www.brandxmetals.com