



PRODUCT ID: CPPIC

DESCRIPTION: An ideal solution for inside corners using 5/16" fiber cement panels. The ends of the panels are concealed by this trim providing a clean finished appearance.

MATERIAL: Aluminum Alloy 6063 T5 **ASTM:** B 221

THICKNESS: Nominal .050

LENGTH: Standard: 10 ft.

FINISH: Standard - Clear Anodized (Architectural 200R1 med. Etch AAM32C10A21)
Also available:

- Alodine® or Chem-Film a.k.a. 'chemical conversion'
- Custom anodized finishes
- Kynar® fluoro-polymer extrusion coating

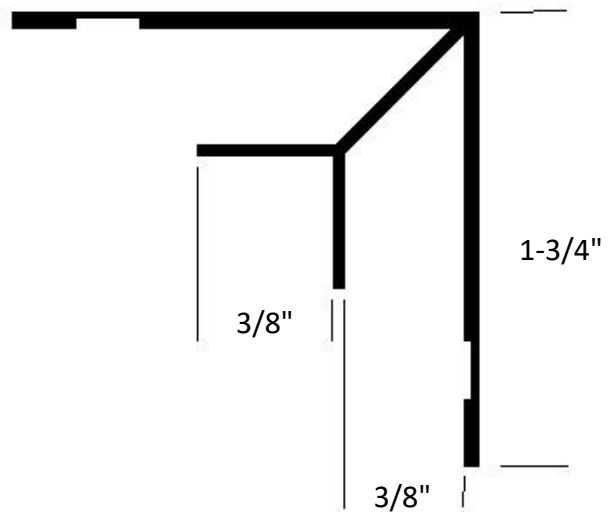
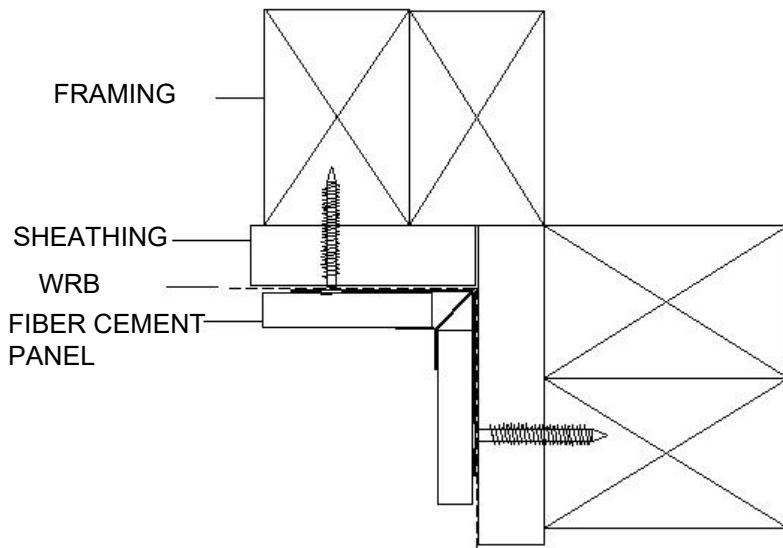

BRAND X METALS, INC.
1641 S. Sinclair St. ♦ Anaheim, CA 92806 ♦ PH: 714-978-3600 ♦ FAX: 714-978-3601
www.brandxmetals.com